



APPLICATION

These attractive, quality built searchlights are suitable for smaller craft where good illumination characteristics, durability and appearances are important factors. These searchlights are approved by the UK Department of Transport Marine Directorate for use on ships' lifeboats according to Chapter 111 of the 1983 amendments of the S.O.L.A.S. regulations.

SPECIFICATION

The following features are incorporated in both the MK1 & M12 searchlights.

- Toughened super clear Optiwhite front glass.
- Polished, electro-brightened super purity Aluminium, parabolic reflector.
- Constructed from marine grade materials and fixings
- Powder coated and stove enamel paint finish
- MK1 & M10 Tilt elevation control $\pm 35^\circ$.
- Tungsten halogen lamp
- Sealing – IP65 Searchlight
- Searchlight weight MK1 3kgs, M12 3Kgs
- Special Cabin dimensions available on request
- External focus control.
- Special Cabin dimensions available on request
- MK1 is fitted with a detachable base and is swivel mounted allowing all round horizontal movement and vertical movement which allows the light to be pointed directly overhead.

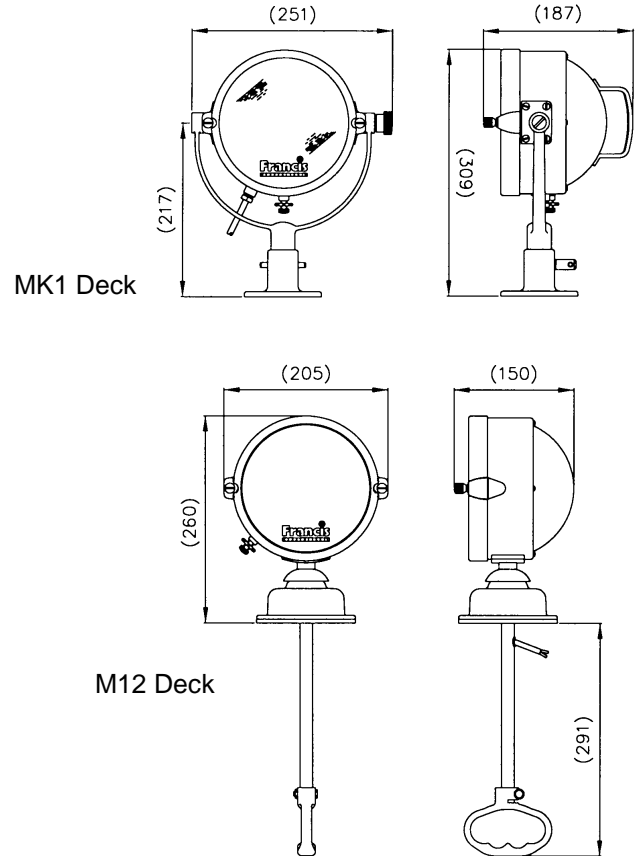

ALL DIMENSIONS IN MILLIMETRES

Base fixing details:

MK1 – 3 holes $\varnothing 8$ on a 81.0 P.C.D.

M12 – 3 holes $\varnothing 6.4$ on a 108 P.C.D. with a centre control clearance hole $\varnothing 45$.

Part Numbers

Type	Finish	Part No
MK1	Paint	A2200
MK1	Chrome	A2201
M12	Paint	A2198
M12	Chrome	A2199

VAC	Lamp life	Range @ 1 Lux	PBCP X 1000	Div	Watts	Lamp No
12v	3000 hrs	405m	164	3.4°	50w	D4051
12v	50 hrs	576m	332	3°	50w	D9849
12v	50 hrs	640m	409	4°	100w	D3018
12v	2000 hrs	492m	242	4.6°	100w	D9848
24v	2000 hrs	438m	191	4.7°	100w	D9850

For more information contact: